

TRIG-STAR PROBLEM LOCAL CONTEST

PRINT NAME: _____

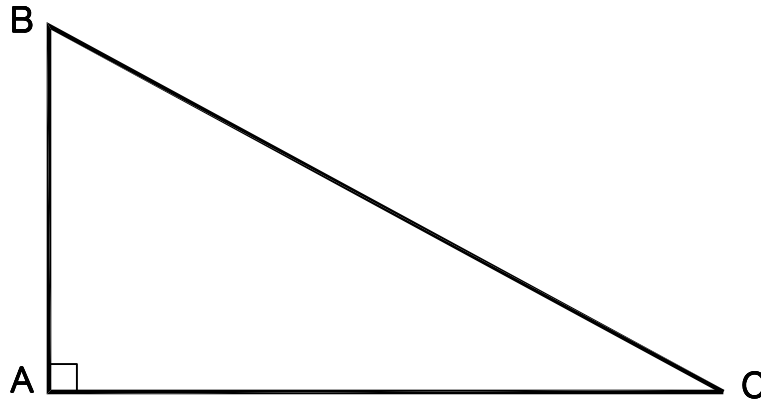

KNOWN: DISTANCE AB = 185.85 DISTANCE BC = 375.75

FIND: \angle CBA = _____ (5 POINTS)

DISTANCE AC = _____ (5 POINTS)

REQUIRED ANSWER FORMAT

DISTANCES: NEAREST HUNDREDTH
 ANGLES: DEGREES-MINUTES-SECONDS
 TO THE NEAREST SECOND

TRIG-STAR PROBLEM LOCAL CONTEST

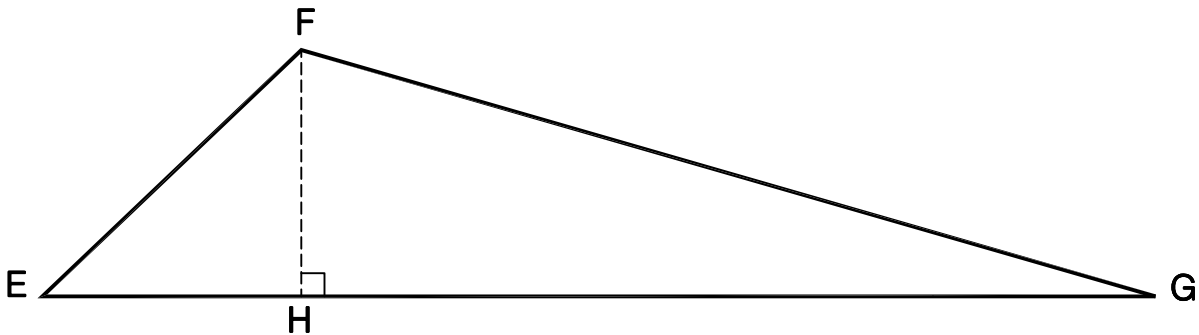

KNOWN: DISTANCE EF = 180.08 \angle EFG = 122°17'07" \angle FEG = 41°51'52"

FIND: DISTANCE EH = _____ (6 POINTS)

DISTANCE FH = _____ (6 POINTS)

DISTANCE FG = _____ (6 POINTS)

DISTANCE GH = _____ (6 POINTS)

\angle EGF = _____ (6 POINTS)

REQUIRED ANSWER FORMAT

DISTANCES: NEAREST HUNDREDTH
 ANGLES: DEGREES-MINUTES-SECONDS
 TO THE NEAREST SECOND

PAGE TOTAL: _____ POINTS

TRIG-STAR PROBLEM LOCAL CONTEST

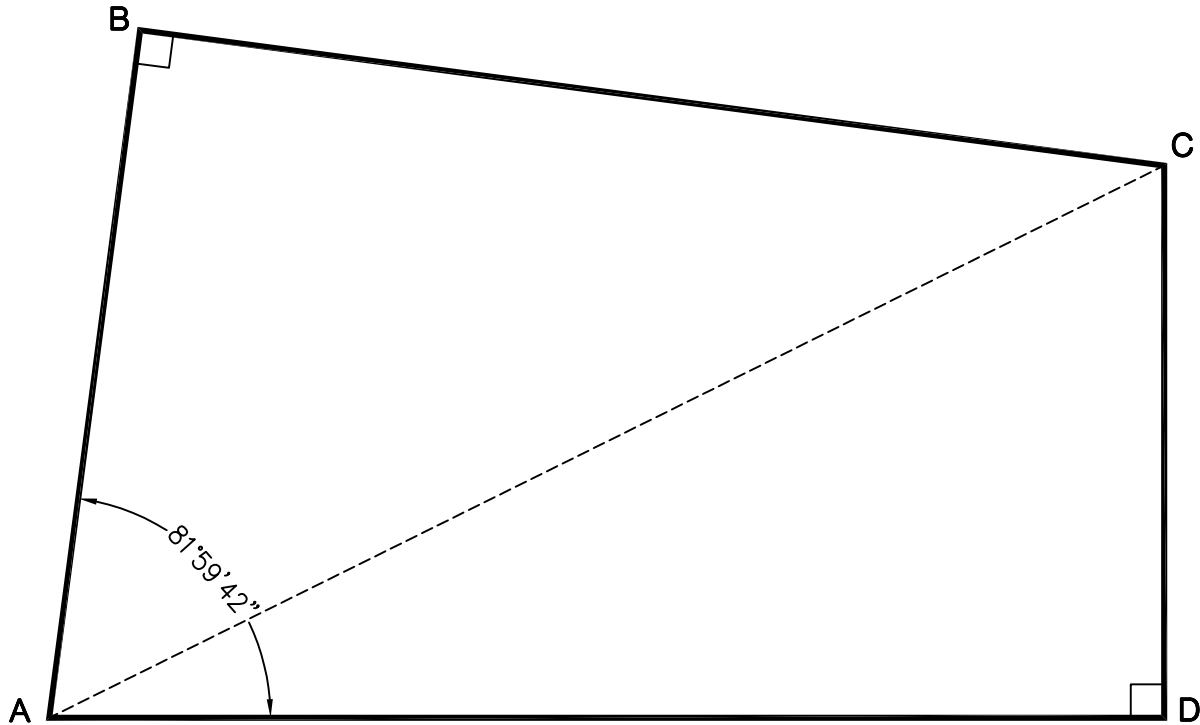

KNOWN: DISTANCE BC = 251.53 DISTANCE CD = 138.98
 \angle BAD = $81^{\circ}59'42''$

REQUIRED ANSWER FORMAT

DISTANCES: NEAREST HUNDREDTH

FIND: DISTANCE AB = _____ (10 POINTS)
DISTANCE AD = _____ (10 POINTS)
DISTANCE AC = _____ (10 POINTS)

PAGE TOTAL: _____ POINTS

TRIG-STAR PROBLEM LOCAL CONTEST

A RAILROAD COMPANY WOULD LIKE TO BUILD A NEW TRACK TO SERVICE A FACTORY. THE POSITION OF A LOADING FACILITY HAS BEEN DETERMINED AND WILL BE AT POINT "E". A SURVEYOR NEEDS TO LAYOUT A CURVE THAT WILL PASS THROUGH POINTS "C", "E" AND "G".

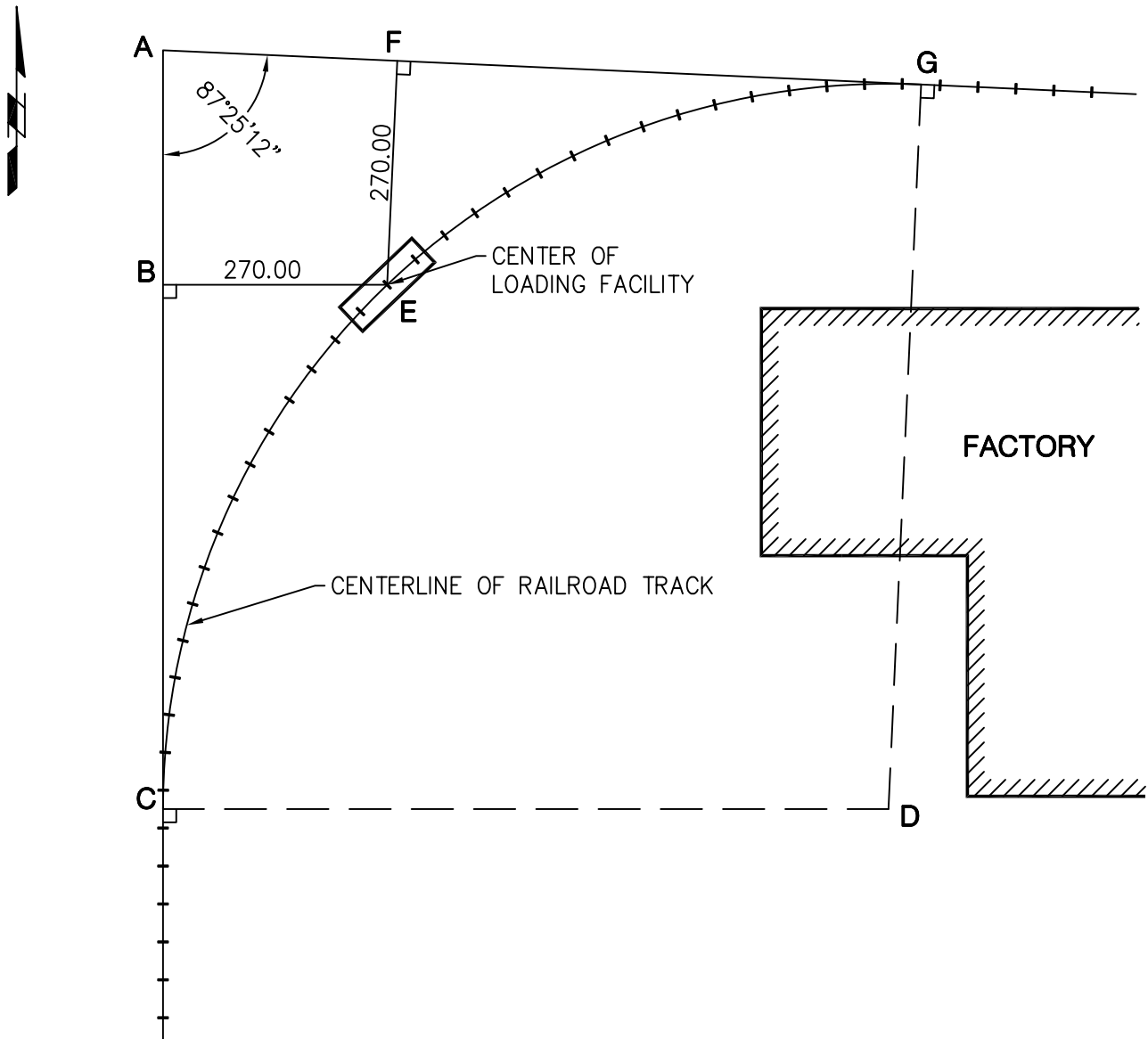

REQUIRED ANSWER FORMAT
DISTANCES: NEAREST HUNDREDTH

- FIND: DISTANCE AB = _____ (7 POINTS)
 DISTANCE BC = _____ (7 POINTS)
 DISTANCE CD = _____ (7 POINTS)
 ARC DISTANCE CE = _____ (9 POINTS)

PAGE TOTAL: _____ POINTS

TRIG-STAR ANSWER KEY LOCAL CONTEST

PAGE 1

$$\sphericalangle CBA = \boxed{60^{\circ}21'21''}$$

$$\text{DISTANCE AC} = \boxed{326.57}$$

PAGE 1

$$\text{DISTANCE EH} = \boxed{134.11}$$

$$\text{DISTANCE FH} = \boxed{120.18}$$

$$\text{DISTANCE FG} = \boxed{440.02}$$

$$\text{DISTANCE GH} = \boxed{423.29}$$

$$\sphericalangle EGF = \boxed{15^{\circ}51'01''}$$

PAGE 2

$$\text{DISTANCE AB} = \boxed{175.72}$$

$$\text{DISTANCE AD} = \boxed{273.55}$$

$$\text{DISTANCE AC} = \boxed{306.83}$$

PAGE 3

$$\text{DISTANCE AB} = \boxed{282.44}$$

$$\text{DISTANCE BC} = \boxed{631.63}$$

$$\text{DISTANCE CD} = \boxed{873.81}$$

$$\text{ARC DISTANCE CE} = \boxed{705.96}$$